

Transport and mixing of cooling water

guidelines and modelling practice

Authors:

M.J. Baptist and W.S.J. Uijttewaal,

with contributions from:

G.S. Stelling and R.J. Labeur

Delft, 29 June 2005

Table of contents

Transport and mixing of cooling water.....	0
1 Introduction.....	2
2 The cooling water guidelines.....	3
2.1 Environmental effects.....	3
2.2 The new CIW guideline in short.....	4
3 Evaluating heat discharges in connection with the CIW guideline.....	5
3.1 Physical processes.....	6
3.2 Simple estimates.....	8
3.3 Assessment with semi-empirical and expert-system methods.....	8
3.4 Detailed Modelling.....	9
3.5 Comparison of case-studies.....	14
4 Routes towards improvement.....	17
5 Optimal modelling strategy.....	18
6 Conclusions.....	19
References.....	21

1 Introduction

Environmental issues related to the release of cooling water are becoming increasingly important. The consequences of climate change and an increased consumption of electric energy will result in substantial releases of heated water into rivers that may have extremely low discharges. Heating up a river to relatively high temperatures can have considerable consequences for the ecological system. With a stronger emphasis on upholding regulations for environmental protection, a cooling circuit which is designed for minimal ecological impact will increase the operational reliability in case of extreme weather conditions and minimal river discharges.

Updated guidelines have been formulated by the national Dutch water authorities in order to protect the environment against undesirable damage (CIW-report, 2004). These guidelines are used to regulate heat releases by industry and power plants and the possibility to comply with these guidelines should be evaluated before a permit can be given. In order to evaluate the consequences of heat releases in rivers and lakes, reliable prognostic models are needed. Most of the time, simple analytical models can be applied, but for more complex situations, a three-dimensional (3-D) numerical hydrodynamic model may be necessary. Boderie & Dardengo (2003) present an overview of the many possible modelling tools for mixing and transport of heat. Although many of these models are suitable, a few of them are used for the Dutch practice.

At this moment, two 3-D models are commonly used for the Dutch practice to predict the local water temperature as a result of transport and mixing of cooling water, i.e. Delft3D-Flow and THREETOX. Rijkswaterstaat wants to have a better insight into these models, and therefore, the focus of this study is on these two models only. To judge these models, it is not only important how they are applied, but also whether the model is in principle suitable for a certain case. This study will address the differences and similarities of both models, their advantages and disadvantages and their use in practice. Since it is generally difficult to judge whether the models themselves and the way they are used is most appropriate for the problem under consideration, a scheme for an 'optimal modelling strategy' will be set-up. Finally, it is conceivable that research should be initiated in order to improve the performance of current 3-D models.

This report is written to the order of the Ministry of Transport Public Works and Water management, RWS-RIZA, project number WIA/1377.

2 The cooling water guidelines

2.1 Environmental effects

First, we give a short overview of the environmental effects of cooling water (Baptist, 1998), since the understanding of these effects has led to the formulation of new guidelines.

The continual distraction of large volumes of water at power stations normally results in some large organisms such as fish being caught upon the fine mesh screens within the cooling water system (*impingement*). Some smaller organisms such as plankton, macrofauna, fish eggs and larvae are drawn through these fine meshes by the pumps, through the pumps and condensers, and subsequently expelled to the receiving waters (*entrainment*). A biocide may be introduced to the cooling water stream at the point of intake in order to control circuit fouling by organisms such as mussels and slime-forming bacteria. Entrained organisms are thus subjected to residual biocide toxicity, as well as to abrasion, pressure and raised temperature. Cooling water effluents typically cause a localised increase in water temperatures and, where chlorination is utilised as a biocide, introduce very low concentrations of residual oxidants.

Cooling water discharges can, therefore, affect living organisms in several ways:

1. Thermal influence caused by a short-term or long-term exposure to high temperature in the discharge area;
2. Thermal damage caused by heating in the condenser;
3. Mechanical damage caused by the screens at the intake (*impingement*), and by the flow through the cooling system (*entrainment*);
4. Toxic damage caused by a detrimental water quality of cooling water.

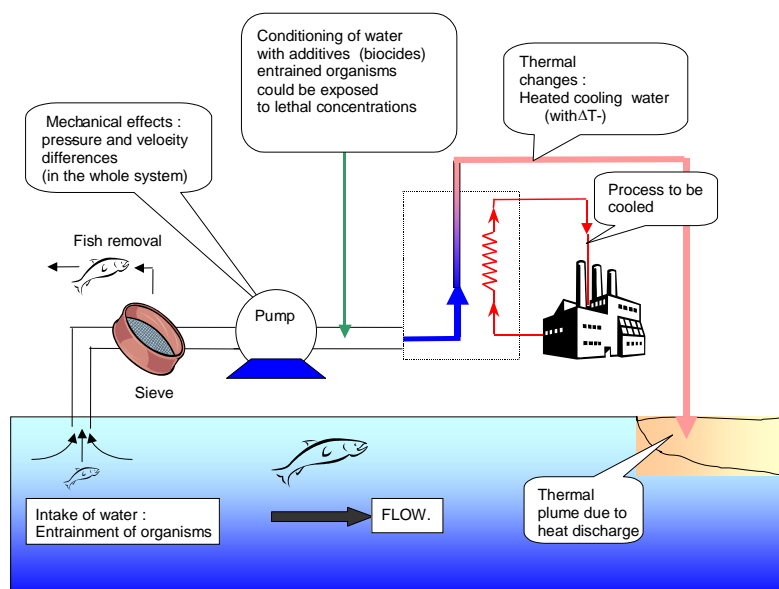

Sketch of a cooling water cycle and its environmental impact, (adapted from CIW-report 2004).

2.2 The new CIW guideline in short

The new guideline is set up by the CIW (Commissie Integraal Waterbeheer) and contains three criteria (that have to be met simultaneously) to protect the aquatic environment:

1. *Subtraction criterion.* Optimisation/minimisation of the intake discharge to minimise entrainment and impingement. The objective is to have no significant effects on populations of organisms in the receiving water. The intake should preferably not take place in spawning areas, nursery areas for juvenile fish and migration routes for fish. Possible effects must be evaluated in the biological spring (freshwater systems 1 March – 1 June, marine systems 1 February – 1 May) and the biological autumn (for marine systems only, 1 September – 1 December).
2. *Mixing zone criterion.* Maximum 25% of the wetted cross-section is allowed to have a temperature equal to or above 30°C for canals/tidal harbours and rivers, and 25°C for the estuaries. In the case of the North Sea, no water with a temperature equal to or above 25°C may reach the bottom.
3. *Heating criterion.* The maximum heating of the receiving water system after complete mixing over the vertical and horizontal, compared to the background temperature, is limited to 3°C for “water for cyprinids”, 2°C for “water for shellfish”, and 1.5°C for “water for salmonids”. The maximum water temperature is set to 28°C for “water for cyprinids”, 25°C for “water for shellfish”, and 21.5°C for “water for salmonids”.

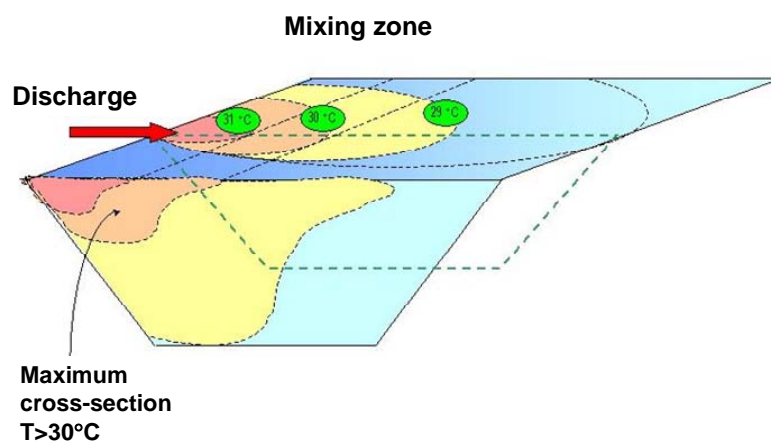

Impression of the temperature distribution around a discharge point (adapted from CIW-report 2004).

Notes and comments

There are no criteria with respect to the water quality of the cooling water defined in the CIW guideline; this is handled in other guidelines.

The new guideline prescribes that there should not be any effects of the subtraction of cooling water on the population of organisms in the *receiving* water. It is not just a theoretical situation, but in some instances a power station subtracts water from one system and discharges into another. It would, therefore, be better to evaluate possible effects on the population in the system from which water is subtracted.

The criteria are subdivided for four different water systems: canals and tidal harbours, rivers, the North Sea and estuaries. For lakes no criteria are defined, here a local impact assessment should be made.

In the case of lakes, the chance of entrainment can be estimated by the volume in which the flow velocity exceeds 0.015 m/s, relative to the total volume of the lake. Numerical flow models, such as those that are evaluated in this study, are able to compute this volume.

The mixing zone and wetted cross-section are not static over time. They may depend on the tidal range, river discharge, wind set-up or other factors. During periods of low river discharge, or slack tide, mixing is low, leading to possible large mixing zones. The guideline proposes to evaluate the mixing zone for a *combination* of a high background temperature and a low discharge that occurs during 2% of a year. Alternatively, the 98% percentiles for low discharge and high temperature can be applied and combined theoretically. In tidal situations, the 98% percentile for discharge is problematic.

A mixing zone criterion for the assessment of water quality standards is also proposed in a recent paper by Jirka et al. (2004).

Cumulative effects of multiple cooling water discharges should always be taken into account.

Once per year, in exceptional circumstances when the background temperature of the water exceeds 25°C, for the duration of one week a mixing zone temperature maximum of 32°C can be allowed.

3 Evaluating heat discharges in connection with the CIW guideline

Provided the CIW guideline, current and planned heat discharges need to be evaluated in order to assess the impact of the heat release and to justify permits that are (to be) given. To that end sufficient information is needed with respect to:

- the design conditions of the process to be cooled;
- the bathymetry and flow of the receiving water body;
- variability of flow conditions;
- the design of the water intake and outlet, location, dimension, discharge, velocities;
- meteorological conditions.

These data are used as input for a calculation method that is considered to represent the physical processes sufficiently well. Since every simplification of reality results in inaccuracies of predictions it is not a question if an estimate of temperature increase contains inaccuracies but rather whether the deviations from reality lay within an acceptable range or not. This should also be seen in the context of the huge variability in the ambient conditions of the river and atmosphere.

3.1 Physical processes

Since the CIW-guideline expresses water quality in terms of acceptable absolute temperature and temperature increase, it appears sufficient to consider the hydrodynamical and thermodynamical processes. Incorporating the biological processes falls outside the scope of this study.

First, a list of the most important hydrologic transport processes is given (Fisher et al., 1979):

1. *Advection*. Transport by an imposed current.
2. *Diffusion (molecular)*. The scattering of particles by random molecular motions.
3. *Diffusion (turbulent)*. The scattering of particles by turbulent motion, considered roughly analogous to molecular diffusion, but with “eddy” diffusion coefficients, which are much larger than molecular diffusion coefficients and not of equal size in all directions.
4. *Shear*. The advection of a fluid at different velocities at different positions; this may be simply the normal velocity profile for a turbulent flow where the water flows faster with increasing elevation above the bed; or shear may be the changes in both magnitude and direction of the velocity vector with depth in complex flows such as in estuaries or coastal waters.
5. *Dispersion*. The scattering of particles or a cloud of contaminants by the combined effects of shear and transverse diffusion.
6. *Mixing*. Diffusion or dispersion as described above; turbulent diffusion in buoyant jets and plumes; any process which causes one parcel of water to be mingled with or diluted by another.
7. *Evaporation*. The transport of water vapour from a water or soil surface to the atmosphere.
8. *Radiation*. The flux of radiant energy, such as at the water surface.

3.1.1 Hydrodynamics

The cooling water circuit affects the flow in the river, channel or estuary in several ways. The amount of water withdrawn from the main water body can be a substantial part of the total discharge. It therefore not only affects the flow around the inlet leading to entrainment and impingement of organisms, it also decreases the flow in a river or canal between the inlet and outlet structure. In any case shortcutting between intake and outflow (recirculation) should be prevented. This is far from trivial in harbour areas and estuaries.

In practice, the discharge of heated water has the largest hydrodynamical impact, and is most difficult to capture in a model and, therefore, receives most attention here. The mutual interaction between the outfall flow and the ambient flow is classified in near field and far field behaviour and depends on the application as well as the flow geometry. In general the following definitions are useful:

- *Near field*: Advection and diffusion is governed by the properties of the incoming jet/plume.
- *Far field*: Advection and diffusion is governed by the properties of the ambient flow.
- As a kind of transitional stage the *mid field* can be distinguished where processes like buoyant spreading are important.

The term ‘mixing zone’, which is used in the CIW-guideline, does not have a direct relationship with the classification in near field, mid field or far field. The 30°C isotherm may be found in any of these fields depending on the outflow temperature, the rate of mixing and the rate of cooling at the surface.

In the near field, the important feature of the warm water release with volume flux Q (m^3/s) from an opening of cross-sectional area A (m^2), is the fact that it introduces a momentum due to its velocity flux. This effect can be quantified in the so called specific momentum flux:

$$M = \frac{Q^2}{A} \quad (1.1)$$

The buoyancy resulting from the difference in density $\Delta\rho$, gives rise to a specific buoyancy flux:

$$B = gQ \frac{\Delta\rho}{\rho} \quad (1.2)$$

These two aspects complicate the prediction of the resulting temperature distribution especially in the area close to the point of discharge which is identified as the near field. The momentum flux and buoyancy flux define a momentum length scale (Fisher et al., 1979, Eq. 9.36):

$$L_M = \frac{M^{3/4}}{B^{1/2}} \quad (1.3)$$

The momentum length scale indicates the length beyond which the effects of buoyancy dominate those of momentum. At smaller distances the buoyancy is not important and the flow is characterised as a jet. At even smaller distances the dimension of the inflow geometry governs the width of the jet, providing the volume flux length L_Q as the effective scale, defined as (Fisher et al., 1979, Eq. 9.10):

$$L_Q = \sqrt{A} = \frac{Q}{\sqrt{M}} \quad (1.4)$$

The ratio of these length scales forms the dimensionless jet Richardson number (Fisher et al., 1979, Eq. 9.40):

$$R_o = \frac{L_Q}{L_M} = \frac{QB^{1/2}}{M^{5/4}} \quad (1.5)$$

The jet Richardson number has a value between 0 and 1. For large values, the buoyant jet behaves like a jet and for small values it behaves like a plume. In the presence of an ambient cross-flow with velocity u_a , the protrusion of the jet or plume into the main stream is expressed in a cross-flow length scale for the jet:

$$L_m = \frac{M^{1/2}}{u_a} \quad (1.6)$$

and for the plume:

$$L_b = \frac{B}{u_a^3} \quad (1.7)$$

Relating these length scales to the dimensions of the flow domain (with width b and depth H) already provides a clue as to what extent the buoyancy flux and momentum flux is important for the near field mixing. These length scales also provide a measure for the resolution needed to resolve the near field of the outfall flow with sufficient detail.

Most of the hydrodynamic aspects of jets and plumes are described in well-known textbooks such as those of Fischer et al. (1979). The semi-empirical expressions found therein, provide a set of tools which is very useful for a first classification of the outfall flow and the choice for the modelling approach.

3.1.2 Thermodynamics

The temperature of the receiving water is not completely governed by the hydrodynamics. Other influences play a role in the total heat balance. Heat exchange takes place via the free surface and the bed material. The former is considered most important and composed of radiation, phase transition (evaporation / condensation) and conduction while the latter consists of conduction only. A proper modelling of the heat exchange at the free surface requires information of the dominant meteorological conditions like wind, cloudiness, air temperature and humidity. With the large variability of the weather conditions and the large uncertainty in the applicability of the model equations for the given conditions the estimate of the heat exchange with the atmosphere contains quite some uncertainty. Since in many cases the heat disappears eventually via the free surface it is important to make a clear choice in this respect with the proper motivation. A detailed overview can be found in Boderie and Dardengo (2003).

In cases where the discharge of the receiving water is large compared with the discharge of cooling water, neglecting the heat exchange has little consequences for the near-field temperature distribution. If there would be any influence, the error would lead to an overestimation of the temperature and is therefore at least not harmful.

In any case the temperature dependency of the water density should be accounted for in order to correctly represent the buoyancy of the plume.

3.2 Simple estimates

In case we would know nothing but the discharges and temperatures of the incoming river water and cooling water, already a conservative guess can be made concerning the criteria for mixing and heating. For the mixing we consider the cooling water discharge as diluted homogeneously over 25% of the full cross-section. While for the heating a fully mixed state is assumed (see also CIW-report 2004).

Deviations from this simple case are found when:

- a. the buoyancy affects the vertical mixing;
- b. the velocity distribution is strongly non-uniform;
- c. the cooling water discharge affects the local flow conditions significantly. In particular when the velocity of the discharged cooling water is significantly higher than the ambient flow, in combination with weak mixing;
- d. heat exchange via the free surface is significant (irradiation of sun light, evaporation, wind).

Though extremely simple and inaccurate, this method can be used to judge whether a certain heat release should be considered at all. It also provides direct insight in the orders of magnitude of the possible discharges as well as an estimate for the associated temperature increases.

3.3 Assessment with semi-empirical and expert-system methods

When more details of the jet development are taken into account, an analysis can be made of the temperature distribution over the cross-section. Using standard formulations for the jet development in the near field and the mixing in the far field, the better representation of the physics should result in more accurate predictions. When this method is devised such that the

predictions are always on the safe side, it can be used as a first assessment to indicate whether a more detailed analysis is sensible.

Its simplicity, speed and flexibility makes this tool also suitable for use in early stages of the design process of an outlet. A large number of alternatives can easily be evaluated resulting in a rapid optimisation. On the basis of these first evaluations it can be decided if a further and more detailed analysis is needed.

This method can be extended towards an expert-system like CORMIX (Jirka, Doneker & Hinton 1996), containing an extensive set of analytical and semi-empirical formulations that apply to most practical conditions. Below an example is provided of the classification scheme as it is used in the CORMIX expert system. Based on this classification, the properties of the plume are determined in greater detail using integral models calibrated with experimental data. The nine classes in the scheme provides also information with respect to the details of the physics that should be incorporated in case a detailed numerical study is envisaged.

FLOW CLASSIFICATION FOR BUOYANT SURFACE DISCHARGES

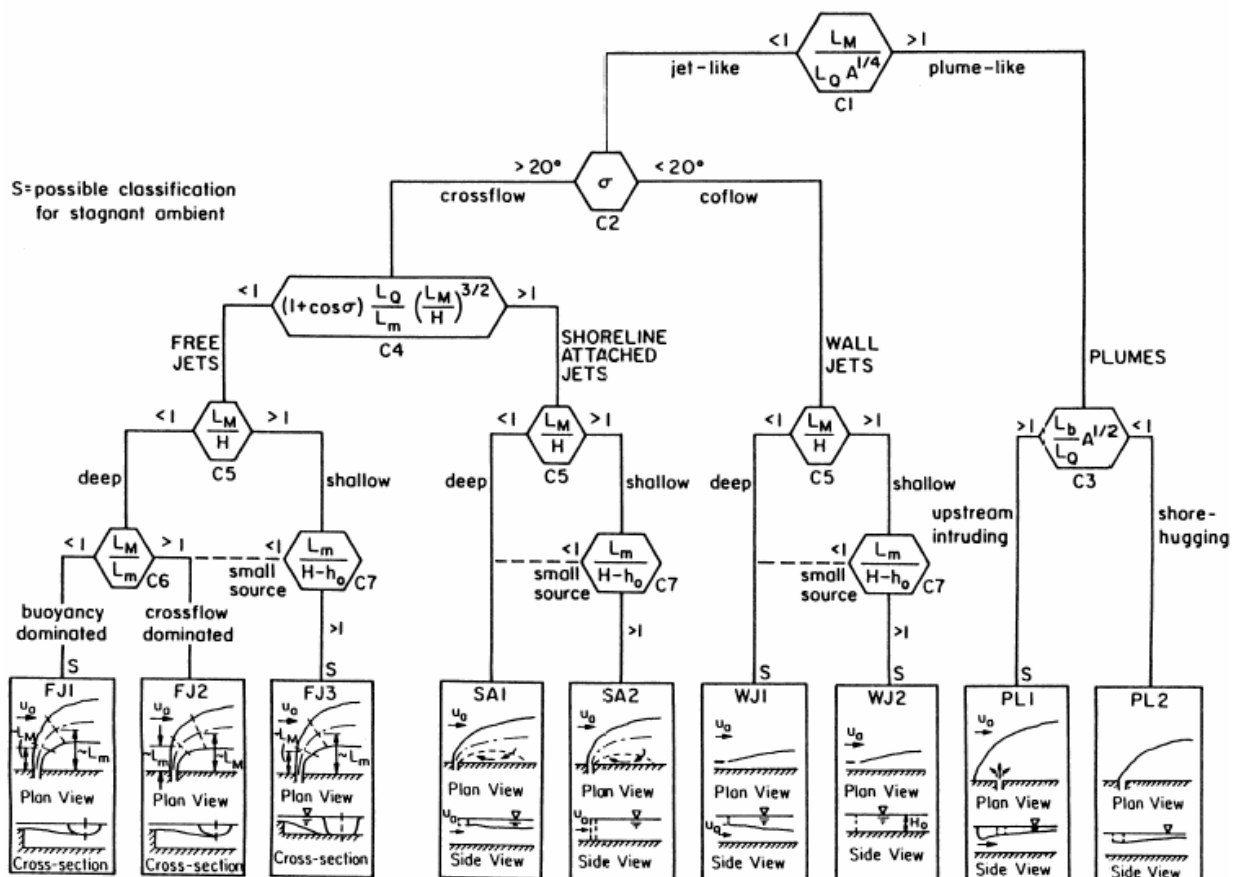

3.4 Detailed Modelling

When considering complex flow geometries with varying discharges and water levels, a need arises to simulate the whole flow domain instead of estimating the properties of the jet/plume

only. Moreover, expert systems cannot be very specific with respect to the local conditions in a complex domain. In numerical models on the other hand, the water motion and water temperature in the domain are represented on a grid that should be dense enough to represent the incoming jet with sufficient detail, while the whole domain should be large enough to capture the far field effects of the plume and to avoid disturbances from the upstream and downstream boundaries.

In this study, two numerical models are addressed that are frequently used by NRG/KEMA and WL | Delft Hydraulics to predict the transport and mixing of cooling water discharge. These models are respectively: THREETOX and Delft3D.

Both are three-dimensional flow models that solve for the ensemble averaged water motion, transport and mixing of heat by the water. This implies that no instantaneous motions are solved and that all contributions of the turbulence are captured in a turbulence model.

Hydrostatic assumption

Both models (applied in the standard way) assume a hydrostatic pressure distribution. For both models, the horizontal water motion is described by means of momentum balances for the two horizontal velocity components. Under the assumption of the water being shallow, the momentum balance for the vertical direction is reduced to the hydrostatic distribution of the pressure. The vertical velocity is consequently obtained from the continuity equation. In cases where vertical accelerations are expected, such as with buoyant plumes and internal waves, this assumption is violated resulting in inaccurate solutions. The example below shows that for a buoyant plume the result of a non-hydrostatic simulation is stable and smooth in accordance with reality, whereas the hydrostatic assumption leads to instabilities and enhanced mixing and thus wrong results (see Zijl, 2002, who compared Delft3D-hydrostatic and CFX non-hydrostatic). In this case the solution is even wrong in the region where the non-hydrostatic effects do not play a role anymore. The non-hydrostatic model is necessary for the proper and stable representation of the near field but also affects the mid field and far field mixing.

The differences in model outcome are quite dramatic in the example shown. In many applications where the vertical velocity is small and the point of discharge is at the free-surface, the hydrostatic model result is probably less problematic.

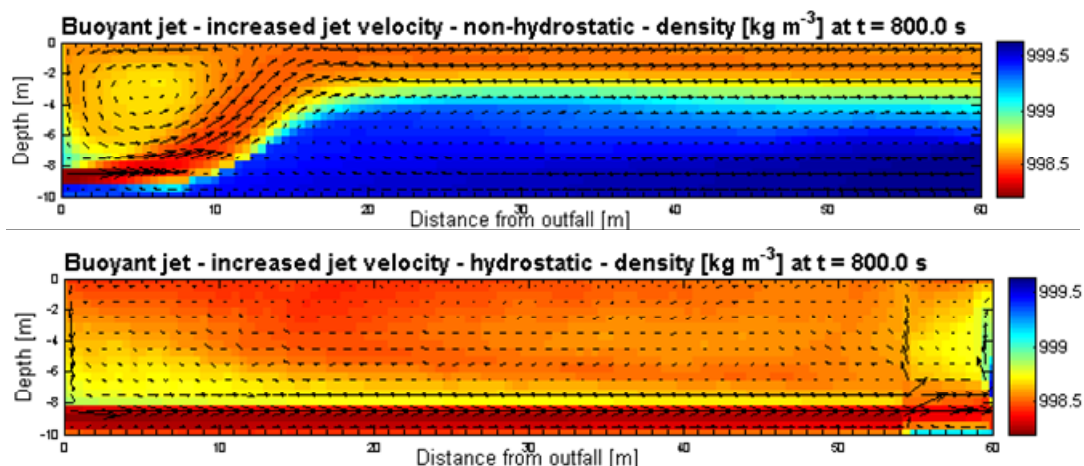

A buoyant jet simulated with a non-hydrostatic model (top) and a hydrostatic model (bottom), showing completely different effect on the mixing. Colors indicate the density in kg/m³.

Turbulence modelling

In both models use is made of the k - ϵ turbulence closure where the vertical mixing of mass and momentum is evaluated from the transport equations for the turbulent kinetic energy (k) and the turbulent dissipation, (ϵ). The effect of buoyancy on the turbulence is accounted for differently in the models. In the THREETOX approach the constant c_{μ} , is corrected for the effects of density gradients by means of stability functions. Care is also taken of the mixing due to internal waves. In Delft3D the effects are accounted for by means of buoyancy flux terms in the equations for k and ϵ . The remaining constants in the k - ϵ model are assigned the standard values in both models. The anisotropy as found in shallow flow turbulence and the use of grid cells that are much larger in the horizontal than in the vertical direction, requires a larger turbulent viscosity for the horizontal mixing than provided by the k - ϵ model. To that end the horizontal eddy viscosity is increased to a value that is set by the modeller, which leaves some room to tune the model. In Delft3D an option exists to derive the horizontal eddy viscosity from a modified Smagorinsky model (HLES).

Computational grid

The size of a computational grid cell determines as to what detail the properties of the ensemble averaged flow quantities can be resolved. For the representation of the most important features of a heat discharge in a river or canal, typically a horizontal resolution of 10 m by 10 m is used (see Section 3.5). Over the vertical dimension the gradients in velocity, temperature and density are higher requiring a higher resolution, typically 10 to 20 layers. In order to represent the variations in bed level without problems of discrete steps and artefacts due to the grid, sigma coordinates are used allowing the grid to adapt smoothly to these variations.

For the horizontal mesh, Delft3D and THREETOX have the option to choose between Cartesian and curvilinear coordinates allowing some flexibility in the alignment of the mesh with the side boundaries.

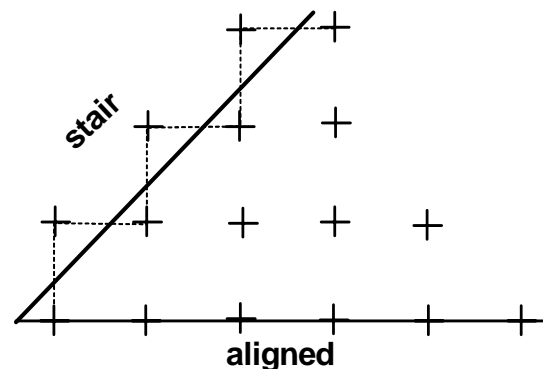

a rectilinear grid makes a skewed boundary rough

The limitation of a rectilinear coordinate system introduces a risk in complex domains where the mixing and side wall friction need to be presented properly. Since a rectilinear mesh allows choosing one orientation of the grid axes only, the grid can be aligned with the orientation of the most important domain boundary. Other boundaries that are not parallel or perpendicular to that orientation will necessarily be represented by a stair-like shape. Such a ragged boundary can have a strong influence on the mixing of mass and momentum up to 4-5 grid cells away from the boundary, with consequences for the flow and temperature prediction in the neighbourhood of such a boundary. It is especially the coarseness of the horizontal grid that causes this influence to extend a significant distance into the domain. In that respect also an influence on the overall flow pattern can be expected and the solution will deteriorate. In relatively narrow and deep channels (like harbours), as well as sharp and deep bends, this can lead to serious inaccuracies. On the other hand, in wide shallow rivers equipped with groynes where bed friction and confinement of the flow by the groynes dominate the flow resistance, no problems caused by the inaccurate closed boundaries are expected. An illustration of the mentioned phenomenon is demonstrated for a bend below.

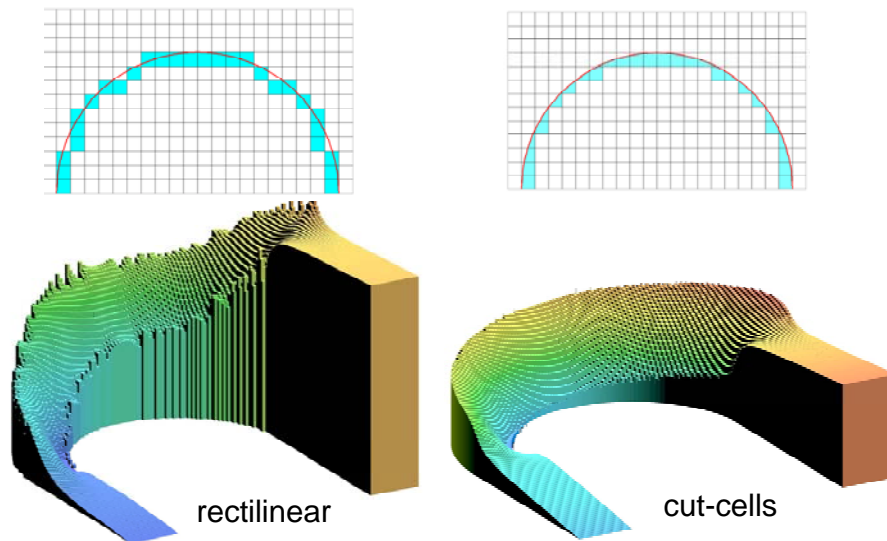

Comparison of water level changes for a flow through a bend for two different implementations of the boundaries. The rectilinear implementation (left) introduces a ragged boundary with a high drop in water level, the cut-cell technique (right) yields a smooth boundary with small losses. The cut-cell technique is not available yet for one of the models.

The total number of grid points is determined by the resolution and the domain size. In a straight channel with a well defined flow the domain can be kept relatively small since the effects of the upstream and downstream boundaries are small. In an estuary however the flow is more complicated due to influences of tidal motion and salinity gradients, requiring a much larger domain to be covered by the computational grid. For the accuracy in the representation of the plume the resolution far away from the outfall does not need to be very high. It would therefore be advantageous when domain decomposition and nesting of domains with different resolution is possible. From the applications it is seen that with the Delft3D model this technique can be used. Still the resolution will never be sufficient to represent the details of the near field behaviour.

Implementation of discharge point

The dimension of the domain that is affected by the discharge is generally much larger than the outfall. Despite the possible use of a locally refined grid, the resolution is generally insufficient to represent the outfall geometry and the discharge flow in much detail. In Delft3D as well as in THREETOX, the outfall is represented on just a few grid points. It can therefore not be expected that the near field of the plume, which is by definition highly influenced by the inflow conditions, is properly represented in the model solution. The simplest way to correct for this is by estimating the development of the discharge plume using an analytical or empirical description of the plume behaviour from the outfall orifice up to a size large enough to be properly represented by the grid. This requires a coupling between the numerical model and the near field description of the plume which is in principle a two-way interaction. The ambient flow has an effect on the plume whereas the introduction of the plume affects the ambient flow pattern. Implementing such a two-way coupling is not trivial and requires careful evaluation (Beleninger & Jirka 2004). For both models at least a one-way coupling is feasible. For Delft3D, applications are already known. Care should be taken of the location where the mass and momentum is introduced such that a realistic profile for the plume is realised.

Boundary conditions

The numerical models require the prescription of boundary conditions at the bottom as well as the free surface. Since the resolution is insufficient to resolve the viscous effect at the bed, the velocity at the first grid point is derived from the assumption of a logarithmic velocity profile. The bed shear stress formulation is directly coupled to the bed roughness.

In nearly stagnant water the effect of wind is not only important for heat exchange but it is also a momentum source driving the flow. At the free surface a shear stress representing the effects of wind is prescribed in both models.

In tidal systems, the boundary conditions vary in place and time and the flow may be affected by density stratification, this leads to complex boundary definitions. Furthermore, averaged in place and time, the cooling water plume may not exceed the temperature limits, but there are occasions where it can, for example at slack tide.

The boundary conditions used for the turbulence properties represented by the k - ϵ equations, are the same for both models. The models assume a local equilibrium between production and dissipation of turbulent kinetic energy at the bed. At the free surface the effect of wind on k is incorporated. The boundary conditions for ϵ are chosen such that the wind-induced flow results in a (nearly) double logarithmic velocity profile.

At the open upstream boundary, standard assumptions are to be made with respect to the distribution of momentum and turbulent kinetic energy. This is usually done in accordance with the logarithmic boundary layer assumptions. At the outflow boundary, the advection of the properties out of the domain is straightforwardly taken care of. Especially with the always imperfect upstream and downstream boundary conditions it is important to minimize their influence by locating them far away from the region of interest. This is most effectively achieved by decomposing the domain in a high resolution part for the region around the outlet, coupled to a part with a lower resolution in the far field and beyond. Delft3D has capabilities to do this, THREETOX has not. For computations with tidal motion and density stratification due to salinity, the open boundaries are chosen tens of kilometres away from the location of interest (see for example case WL2 below).

Heat flux models

The Delft3D model provides a choice from five different heat flux models. The various contributions to the heat balance can thus be accounted for including solar and atmospheric radiation, back radiation (from the water), evaporation and convection. In the simplest model known to be used in cooling water studies, the heat balance is simplified in the form of an excess temperature model. The heat flux is considered to be proportional to the temperature difference between the water at the free surface and the air above it. The wind speed is the only additional effect that is accounted for. With the many models available it is the modeller selecting an appropriate heat flux model in combination with the available data regarding typical weather conditions and other influences.

The THREETOX model provides one heat flux model that accounts for the same properties: atmospheric radiation, back radiation (from the water), evaporation and convection. Some more attention appears to be paid to the properties of the wind field and the properties of the atmospheric boundary layer and their effects on heat transfer. It looks like these properties are not used in such detail for the transfer of momentum. In principle both models allow the modelling of a rather extensive heat balance which appears sufficient to estimate the heat loss through the free surface, especially in view of the large variability and uncertainty of the ambient conditions in time and space. The calculated local water temperature is used to determine the density of the water and subsequently the pressure distribution. The atmospheric fluxes in both models are calculated from formulas that are applicable for spatially homogeneous turbulent flow. For coastal areas this approach should be improved taking in account internal boundary layers.

Summary

Since no benchmark tests are known, it is hard to judge differences in performance beforehand on the basis of the model descriptions. It is assumed that the models are meticulously tested such that the equations that are said to be solved are solved in a robust way.

In the context of simulating buoyant plumes, both models suffer from the same shortcomings that impede a proper simulation of the near field mixing as well as the representation of the outfall details. It is important to realise that an instable modelling result for the near-field can affect the far-field outcome as well. For many detailed aspects regarding the discretisation and treatment of boundary conditions it is difficult to assess their effects in combination with the other parameters that are set in the models. It would be interesting to see in what respect a study of identical cases with the different models and performed by different modellers, lead to comparable conclusions. For example the choice of the grid dimensions in horizontal and vertical direction in combination with the use of rectilinear and curvilinear coordinates could affect the results. The same holds for the choice of the horizontal eddy viscosity and the locations of the upstream and downstream boundaries. The knowledge and experience of the modeller are therefore important factors in these applications.

On the other hand, the quality of the model computations in real-world studies should be assessed in view of the requirements set by the permit, and the measurement data that is available. In many cases, the consequences for the permit can be made clear even without state-of-the-art three-dimensional models.

3.5 Comparison of case-studies

3.5.1 Six case studies

To evaluate the current practice in modelling cooling water discharges, a number of recent studies performed by NRG/KEMA with THREETOX, and WL | Delft Hydraulics, with Delft3D-Flow, were collected. The studies are coded as follows:

NRG1: Heling, R., Maderich, V, Morgunov, M. & Janssen, B. (2003a). Cooling Water Discharges in ARK; Evaluation of the impact on the aquatic environment by the 3D thermo-hydrodynamic model THREETOX. Arnhem, NRG report 20944/03.55452/P.

NRG2: Heling, R. Maderich, V. & Koshebutsky, V. (2003b). Cooling Water Study; Optimalisation of discharges on river and lake systems. Arnhem, NRG report 91103.55251/P.

NRG3: Heling, R., Maderich, V., Koshebutsky, V. & Janssen, B. (2004). Evaluation of the Cooling Water of the Gelderland-13 Power Plant; Modelling the cooling water in the Waal River near Nijmegen by THREETOX. Arnhem, NRG report 21207/04.57969/P.

WL1: De Goede, E.D. & Kleissen, F.M. (2004). Az-Zour North Hydraulic Studies & Marine Environmental Assessment, Part 1: Set-up and calibration of the hydrodynamic model. Delft, WL | Delft Hydraulics report Z3420.10.

WL2: De Goede, E.D. (2005). Sloecentrale Vlissingen-Oost; Additional scenarios based on new cooling water criteria. Delft, WL | Delft Hydraulics report Z3971.00.

WL3: Wijdeveld, A. (2003). Warmtemodel Chemiehaven. Delft, WL | Delft Hydraulics memo Q3647.

In the following table the main characteristics of these studies are listed, as they could be found in the reports. The classification in midfield and farfield is based on the model domain: midfield indicates a model application that describes a relatively small area around the outfall, where a fine grid is applied. Farfield indicates a model with a large domain around the outfall. None of both models are able to accurately describe the nearfield.

	NRG1	NRG2	NRG3	WL1	WL2	WL3
Type of study	example study	research study	example study	impact study	impact study	example study
Type of system	canal	hypothetical river & lake	river	sea	tidal harbour or estuary	tidal harbour
Near, mid, far	midfield	midfield	midfield	mid+farfield	mid+farfield	mid+farfield
Type of grid	rectilinear	rectilinear	rectilinear	curvilinear	curvilinear	curvilinear
Sim. duration	2 days	max. 6 hours	2 days	5 days	15 days	9 days
Gridcell size	10x10m	lake:10x10m river:10x4m and 6.67x4m	10x10m	variable, min. 50x50m	variable, about 25x25 m	variable, min. 20x30m
Vertical layers	15	26	20	10	10	9
Layer distr.	fixed perc.	fixed 0.15m	fixed perc.	10% of depth	10% of depth	fixed perc.
Hydro. bound.	1 discharge, 1 static waterlev.	river: discharge lake: open	discharge and WL measured	tidal bound.	1 discharge + 1 tidal bound.	2 discharge + 1 tidal boundary
Hor. Eddy visc.	Smagorinsky	Smagorinsky	Smagorinsky	1 m ² /s	0.1 m ² /s	
Bed friction	C _D =0.0025	C _D =0.0025	C _D =0.0025	Chezy 65 m ^{1/2} /s	Manning 0.022-0.026 s/m	
Water temp.	Measured	23°C	from Lobith and measured	measured	4 scenarios	scenarios
Wind speed	Meteodata	0 or 10	Meteodata	Meteodata	constant 7 m/s	constant 4 m/s
Wind direction	Meteodata	90°	Meteodata	Meteodata	SW, 225°	SW, 225°
Air temperature	Meteodata	23°C	Meteodata	Meteodata	--	Equal to background water temp.
Rel. humidity	Meteodata	50%	Meteodata	Meteodata	--	--
Cloudiness	Meteodata	50%	Meteodata	--	--	--
Baromet. press.	Meteodata	1010 mbar	Meteodata	Meteodata	--	--
Validation with measurements	No	No	Yes	Yes	No	No

NRG1. The study by Heling *et al.* (2003a) is an example case study into the detailed 3-D modelling of cooling water discharge in a canal. The model is set-up for mid field effects (in the report, the term near field is used). A very fine rectilinear grid of 10x10 m is applied in a rather small (the model boundaries are too near the outfall locations) model area. It is stated in the report that a larger model area would require an excessive calculation time. Air conditions were obtained from meteo data for the period 11 and 12 August 2003, during a heat stroke. Hydrodynamic boundaries and conditions are not entirely clear. Validation with measurements was not carried out. The detailed results, therefore, are merely indicative with respect to the three-dimensional patterns, but more general conclusions on mixing and dispersion can be made. As an additional remark, the subtitle of this study does not cover the contents, since in our view, no impact on the aquatic environment has been evaluated.

NRG2. The study by Heling *et al.* (2003b) is a theoretical research study in which a cooling water discharge is simulated in a hypothetical, idealised river and a hypothetical, idealised lake. Various scenarios for the vertical position of the outfall, the discharge velocity, outfall size, discharge temperature, wind speed and wind direction were defined and evaluated. Conclusions with respect to stratification, buoyancy effects, heat fluxes to and from the atmosphere and plume dispersal were drawn.

NRG3. The study by Heling *et al.* (2004) is an example case study of the discharge of cooling water into the Waal river on 11-12 August 2003 and 3-4 December 2003. The period of 11-12 August 2003 showed extreme conditions of a high background temperature and a low river discharge. Input data of a high quality has been used, both for the atmospheric conditions as the hydrological conditions. Validation with measurement data on the 3rd of December was carried out. Temperature isolines matched the simulations reasonably well. However, it is not made clear in the report at what depth the measurements were taken and at what depth the simulation is presented. A vertical profile of temperature showed, to our opinion, that there was a rather steep temperature decrease from 0.5 m to 1.0 m depth, which was not simulated accurately. Overall, the model gives good results for the plume behaviour in a river.

WL1. The study by De Goede & Kleissen (2004) investigates the possible cooling water plume behaviour for a planned power station and desalination plant in Kuwait. The modelled area is nested in a large model. Both an excess temperature model as well as an absolute temperature model is applied. An extensive data set was gathered to calibrate and validate the model. Results for water levels and currents were in good agreement with the measurements. Results for temperature were in reasonable agreement with the measurements. The report showed that an excess temperature model could be applied in this study. A horizontal eddy viscosity and diffusivity of $1.0 \text{ m}^2/\text{s}$ was applied.

WL2. The study by De Goede (2005) simulates the cooling water discharge for a planned power station in a tidal harbour. Different scenarios for background water temperature, outfall discharges and outfall temperatures were evaluated. Use is made of an excess temperature model. A curvilinear grid was applied, within a larger grid, using domain decomposition. This allows for enough model detail where it is wanted, in combination with far enough boundary conditions and possible long computation times. A constant eddy viscosity was applied over the entire model domain with the value of $0.1 \text{ m}^2/\text{s}$. A recommendation was made to deal with the 98% discharge percentile in tidal situations.

WL3. The study by Wijdeveld (2003) is an example case study into the detailed 3-D modelling of cooling water discharge in a complex tidal harbour system. The model that has been set-up in this study is called a demomodel. Mid field, as well as far field effects were investigated for various outfall scenarios. Air conditions that affect the air-water interface for cooling down the hot water plume were modelled in a simple way. Important information with regard to the eddy viscosity is missing. No validation with measured data has been done. The results, therefore, do not give more than an indication of possible plume layouts in three directions. More general conclusions on stratification, vertical currents and farfield temperatures can be made though. In addition, horizontal large eddy simulation has been applied in this study, which may yield a better insight in local turbulence.

3.5.2 Remarks

The major shortcoming that is found in both models is that for the known applications the hydrostatic pressure assumption is used. In view of the CIW guidelines this could be a relevant issue, not only for the near field effects, but also for the far field spreading of the plume. An instable computation of the near field could lead to an overestimation of the cross-section of the plume. It is furthermore conceivable that when the receiving water is stratified, the formation of internal waves requires a non-hydrostatic approach.

In the case-studies mentioned above the near field is treated in a very simple way. The discharge is located on one or a very small number of grid cells allowing no accurate representation of the

discharge conditions. At best the total discharge and average velocity is correctly represented. More details like turbulence intensities and inflow profiles appear absent, which is by definition a problem for the representation of the near field.

Assessing the applications of the models it is noteworthy that the Delft3D applications typically concern coastal areas influenced by tidal motion while the THREETOX applications are smaller and located further upstream. This could be a coincidence. The dimensions of the computational grid are much larger when tidal motion plays a role and all information of the estuarine flow needs to be accounted for in a nested grid with tens of kilometres as a horizontal dimension. The river reaches modelled by NRG are typically of the order of one kilometre. Although the mentioned differences are not a direct shortcoming of the models it shows the differences in use and partly the capacity and flexibility of the models.

4 Routes towards improvement

The evaluation of the modelling approach gives routes towards improvement of the 3-D models:

- The hydrostatic pressure assumption is known to have the most important consequences for the near field behaviour of a buoyant plume (Zijl, 2002) and affects the mid field and far field spreading, as well. It is therefore plausible that an improvement can be expected by using a non-hydrostatic approach. It is clear that the strongest effects are found with the largest density and thus temperature differences between the receiving and discharged water.
- The proper representation of the near field also depends on an implementation of the outfall flow with inclusion of the physical processes that affect the mixing close to the outlet. Care should be taken of the usually under-resolved outlet up to the dimensions where the plume is sufficiently well resolved on the computational grid (Bleninger & Jirka 2004).
- Another aspect that could be taken into account to improve the models is the heat exchange via the free surface and bed material. This requires much effort regarding validation, and improved modelling will not necessarily lead to significantly better predictions.
- Finally, improving turbulence models is a rather laborious activity with little chance on success. At best detailed studies could be performed using a full 3D Large Eddy Simulation where virtually all physics is included. The results of such studies could then be validated by experiments and further parameterised to improve the engineering models. A similar procedure could be performed for the heat balance. However, for the applications under consideration this might not be worth the effort especially when considering the uncertainties in the detailed conditions for each application.

Suggestions for further testing

To put the 3-D models to the test, it is recommended to first validate both models on existing laboratory data, and also include a non-hydrostatic model application. In order to further analyse the models and detect possible shortcomings of the models and the way they are used in real-world situations, it is recommended to make an inter-comparison of both models for a non-trivial case study. When field survey data are present these would be interesting for a bench mark test. If not, a measurement campaign could be organised.

At last, new, well-conditioned laboratory experiments could be considered, focussing on the near-field behaviour of buoyant discharges.

5 Optimal modelling strategy

An important question is: what is the optimal modelling strategy? In other words, when should one apply what type of model?

For a river with a well-defined cross-sectional area and a known discharge distribution in time and space, the far field temperature is relatively easy to estimate with simple analytical formulae. The near field and mixing zone, however, remains the most difficult and therefore the most interesting part since most uncertainties with respect to the modelling details and the boundary conditions are found there. A complicated situation is encountered when the receiving water body is (nearly) stagnant. In those conditions the near field behaviour is dominant in a much larger part of the domain, whereas the whole mixing process is affected more strongly by subtle processes like stratification, heat conductance, irradiation and evaporation. The meteorological conditions like wind, humidity, and cloudiness require much attention in these cases.

Firstly, we derive a set of criteria for a desired super-model that can handle a wide variety of outfall cases. Next, we will choose for what cases this super-model is needed and for what cases other models are suitable as well. Knowing that every model has its limitations, whether it is a simple or a complex model, one could consider less laborious procedures that provide a rough estimate of the temperature distribution in cases where this is sufficient (see CIW-report, 2004).

First of all, a super-model should include the possibility to have non-hydrostatic pressure distributions for the near field. Apart from the proper representation of the physical processes in the near field, the non-hydrostatic modelling is also important to allow a stable evolution of the rising plume in the mid field and may affect the far field. In Zijl (2002) a very efficient method is proposed for the implementation of non-hydrostatic effects with only a slight increase in computational effort.

Secondly, a super-model should be able to represent the outfall configuration and its effect on the near field. To describe the exact details of the outfall configuration in a numerical (non-hydrostatic) model, a grid with a too fine resolution with respect to the computational effort, is needed. To that end, a dynamic coupling of the numerical model with the near field expert-system CORMIX could be an option, as suggested by Bleninger & Jirka (2004). On the other hand, it should be realised that CORMIX has got its limitations, as well. For situations where two outfalls affect each other, for complex bathymetries, for low flow velocities and for tidal situations, the uncertainty of the model outcome increases. A dynamic coupling of CORMIX and a 3-D model with a detailed representation of the inflow conditions and local bathymetry makes use of the advantages of each approach.

Thirdly, a super-model should allow for nesting a high-resolution computational grid into a larger domain where the resolution can be chosen much lower. This is a very effective way to displace the influence of the open boundaries away from the region of interest. An alternative approach is found in using an unstructured grid, with a local refinement near the outfall.

A prescription of tidal motion and density distribution is properly taken care of at large enough distance. For conditions and areas where stratification is not very important, and far away from

the mixing zone, the computations could be performed on a two-dimensional horizontal grid (2-DH) dealing with a depth-averaged simulation. At such a distance lateral mixing and longitudinal dispersion are the dominant spreading and dilution mechanisms.

Such a super-model does not exist yet, but it may be reached by coupling various models for various regions as sketched in the figure below.

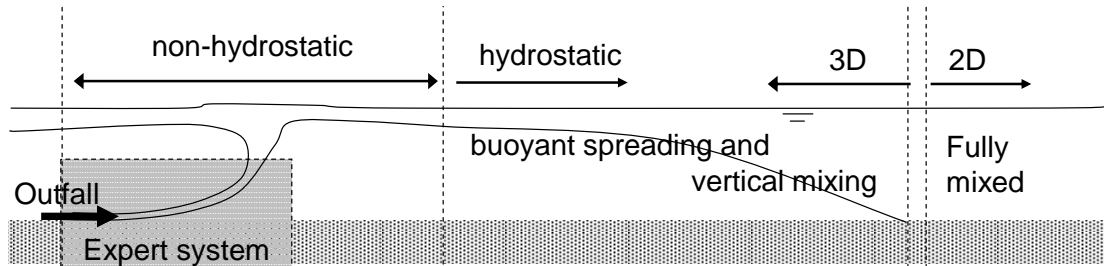

Specific regions require a sophisticated modelling approach; remote areas can be treated simpler.

We can now use the physical properties of the outfall flow as defined in section 3.1 to determine what the optimal modelling strategy is for a given configuration. In line with the above, the classification scheme as applied with the expert-system CORMIX, section 3.3, can readily be used for prescribing the modelling requirements:

1. The classes FJ3, SA2 and WJ2 are vertically well-mixed and can be modelled with a 2-DH model.
2. The classes FJ1, PL1 and PL2 are buoyancy dominated and require non-hydrostatic modelling. A proper representation of the near-field is very important here, thus a dynamic coupling to CORMIX might be the proper modelling strategy especially when the dimensions of the outfall geometry are small in comparison with the grid resolution.
3. The remaining classes FJ2, SA1 and WJ1 could be represented using a hydrostatic 3-D model.

Regarding the realistic representation of the bed and wall boundary details, the classes SA, WJ and PL are most critical. Furthermore, even when near field effects are not dominant, a small computational grid size should be selected.

6 Conclusions

This study has addressed the differences and similarities of Delft3D-Flow and THREETOX, their advantages and disadvantages and their use in practice.

It can be concluded that the differences between Delft3D and THREETOX are generally small. Both models solve the Reynolds averaged shallow water equations under a hydrostatic pressure assumption, both apply a $k-\epsilon$ turbulence model (with some differences in the details of it), both make similar use of (a) heat balance model(s). Also the option to choose between rectilinear and curvilinear grids is present in both models. In the case-studies addressed in this report rectilinear coordinates were mainly used in the THREETOX model while in all cases with Delft3D curvilinear grids were used.

An advantage of the Delft3D grid is that domain decomposition and nesting of the grid allow to define the open boundary conditions far enough away from the area of interest without leading to

excessively high computational times. Practical applications of both models showed the differences in use, which will be partly due to the capacity and flexibility of the models.

Both models are applied in practice using a hydrostatic pressure assumption. A study by Zijl (2002) has shown that the consequences for the near field can be significant. A better representation of the near field plume behaviour can be obtained by applying non-hydrostatic pressure distributions. Moreover, this is also important for a stable spreading of the plume in the mid field and far field. In view of the CIW mixing guideline this could be a relevant issue. A non-hydrostatic model is CFX and Delft3D is also capable of computing the mixing with a non-hydrostatic pressure distribution, but it has not been applied for real-world cases yet. To describe the exact details of the outfall configuration in a numerical non-hydrostatic model, a grid with a too fine resolution with respect to the computational effort, is needed. To that end, a dynamic coupling of the numerical model with the near field expert-system CORMIX could be an option, as suggested by Bleninger & Jirka (2004).

In order to judge which properties of the flow are important and therefore need to be included in the modelling approach, a scheme for an optimal modelling strategy can be used. The scheme as proposed here is based on the CORMIX classification scheme for buoyant surface discharges and couples the length-scale approximations for a plume of jet (section 3.1.1.) to the preferred modelling strategy.

A workshop was held in which experts from RIZA, NRG/KEMA and WL | Delft Hydraulics participated. Prof. Gerhard Jirka from Karlsruhe University in Germany was invited because of his extensive experience with the subject. The minutes of this workshop are reported in a separate document. In short, the discussion of the workshop followed two main lines. One was on the guidelines themselves and the obligations for the industry to comply with them. The other was on possible modelling strategies to determine the mixing zone properties.

The main findings of this workshop are:

1. Post-commissioning monitoring is advised in order to give a permit only after it is proven that the industry complies with the regulations. This is especially advisable for complex outfall situations where the model results indicate exceeding the temperature limits.
2. It is not so much the model, but the modeller that determines the reliability of the model outcome. In view of the small differences between the two models this appears more important than the choice which model to use.
3. It is recommended to obtain adequate measurements to validate the model results. When data is lacking, the many degrees of freedom to fit the results to the data may have the consequence that even with a faulty model, a good fit can be obtained.
4. Non-hydrostatic modelling does not only improve the near field prediction, but it may also improve the far field prediction.
5. A desired modelling tool should have a dynamic linkage between an expert system like CORMIX, and a non-hydrostatic numerical model.
6. The model results should be assessed in view of the requirements set by the permit, in many cases the answer whether an outfall can fulfil the criteria is relatively easy to give.

References

- Baptist, M.J., 1998. EIA's on cooling water discharge in the marine environment of The Netherlands and The United Kingdom. WL report Z2309.00
- Bleninger, T. & Jirka G.H., (2004) Near- and far-field model coupling methodology for wastewater discharges. Porc. 4th Int. Symp. Environmental Hydraulics, Hong Kong.
- Boderie, P. & Dardengo, L. (2003) Warmtelozing in oppervlaktewater en uitwisseling met de atmosfeer. Report Q3315, WL | Delft Hydraulics
- CIW-report (2004) Beoordelingssystematiek warmtelozing. Draft report Rijkswaterstaat.
- Fischer H.B., List, E.J. Koh, R.C.Y., Imberger J., and Brooks, N.H. (1979), Mixing in inland and coastal waters. Academic Press, London. ISBN 0-12-258150-4, 497 pp.
- De Goede, E.D. & Kleissen, F.M. (2004). Az-Zour North Hydraulic Studies & Marine Environmental Assessment, Part 1: Set-up and calibration of the hydrodynamic model. Delft, WL | Delft Hydraulics report Z3420.10.
- De Goede, E.D. (2005). Sloecentrale Vlissingen-Oost; Additional scenarios based on new cooling water criteria. Delft, WL | Delft Hydraulics report Z3971.00.
- Heling, R., Maderich, V, Morgunov, M. & Janssen, B. (2003a). Cooling Water Discharges in ARK; Evaluation of the impact on the aquatic environment by the 3D thermo-hydrodynamic model THREETOX. Arnhem, NRG report 20944/03.55452/P.
- Heling, R. Maderich, V. & Koshebutsky, V. (2003b). Cooling Water Study; Optimisation of discharges on river and lake systems. Arnhem, NRG report 91103.55251/P.
- Heling, R., Maderich, V., Koshebutsky, V. & Janssen, B. (2004). Evaluation of the Cooling Water of the Gelderland-13 Power Plant; Modelling the cooling water in the Waal River near Nijmegen by THREETOX. Arnhem, NRG report 21207/04.57969/P.
- Hunik R. & Koopmans, G. (2003), Studie naar parameters voor verspreidings modellen van koelwater. Report 50331042-KPS/TPE03-1113, KEMA Arnhem
- Jirka, G.H., Bleninger T., Burrows, R. & Larsen, T. (2004), Management of point source discharges in to rivers: Where do environmental quality standards in the new EC-Water Framework Directive apply? J. River Basin Management Vol. 2(3).
- Jirka, G.H., Doneker, R.L. & Hinton S.W. (1996) User's manual for CORMIX, A hydrodynamic mixing zone model and decision support system for pollutant discharges into surface waters.
- Wijdeveld, A. (2003), Warmtemodel Chemiehaven. Delft, WL | Delft Hydraulics memo Q3647.

Zijl, F. (2002), On the effect of non-hydrostatic simulation on buoyant jets. MSc-report Delft University of Technolgy.